

# Series SAS-SAM

Absolute encoder with SSI interface.  
ø58mm with semi-hollow shaft

## Mechanics data

<b>Cover:</b>	Aluminium
<b>Body:</b>	Aluminium
<b>Shaft:</b>	Stainless steel
<b>Bearings:</b>	2 ballraces
<b>Weight:</b>	480gr.
<b>IP protection:</b>	IP64
<b>RPM:</b>	6000 Max
<b>Torque:</b>	< 5Ncm
<b>Moment of inertia</b>	50gcm <sup>2</sup>
<b>Shaft Load:</b>	Ass. 50N - Rad 50N



Dimension in mm

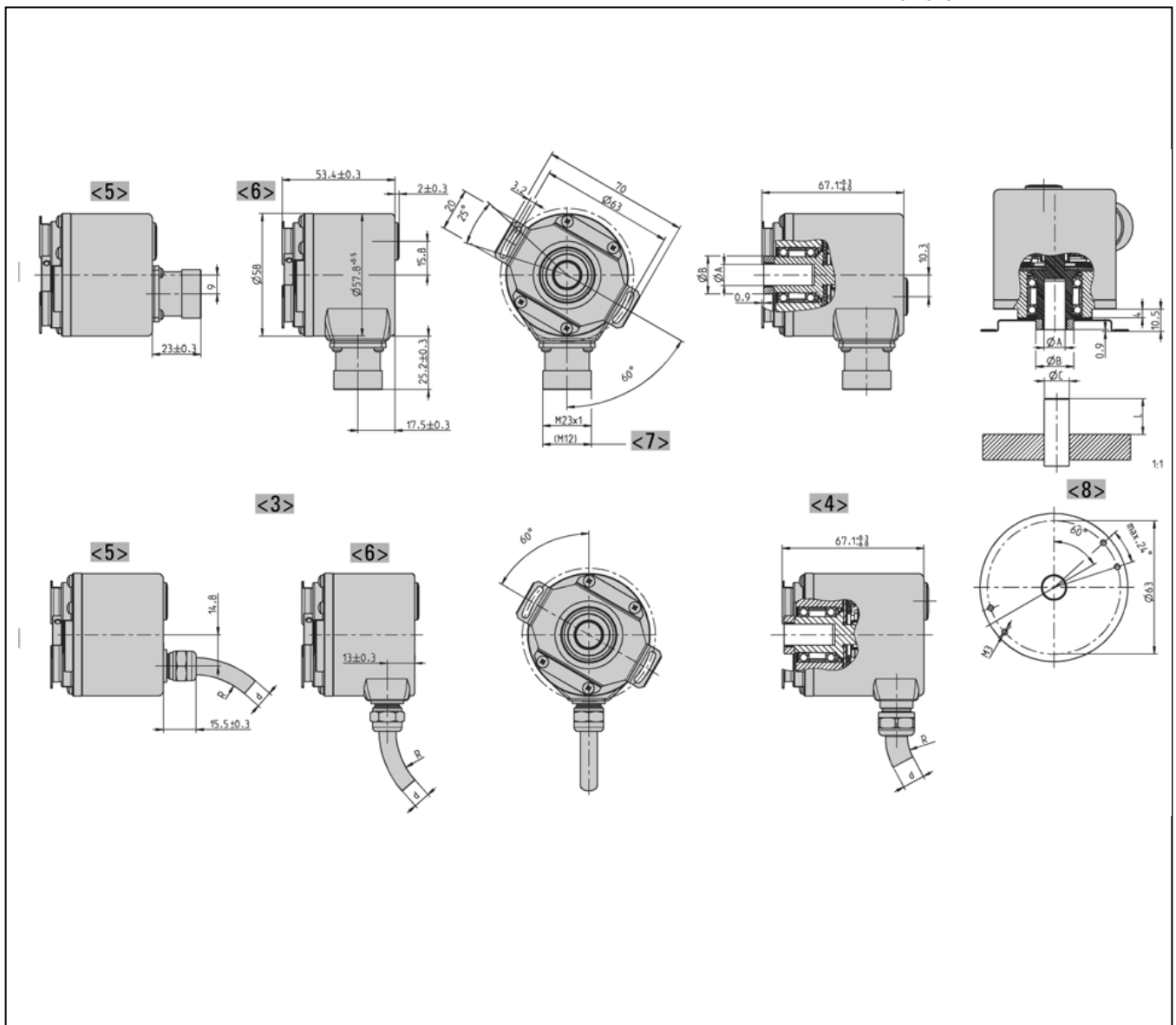

# Series SAS-SAM

## Electronics Data

Resolution: ST: Single turn max 17 Bit  
 MT: Multiturn 29 bit (17 Bit ST - 12bit MT )  
 Power Supply: 10-28V +/- 5% (5V version in option)  
 Current Consumption: 160mA  
 Interface: SSI / BiSS C  
 Monoflop: 20usec  
 Output Data: RS422  
 Output Code: Gray or Binary  
 Operating Temp: -20/+80°C

## Ordering Code

*	*	*	*	*	*	*	*	/	*	/	*
Series			Shaft	Flanges	Output	Connections	Option		BITsg/BITmg		
Ø58mm <b>SAS = Single Turn</b> <b>SAM = Multi Turn</b>			0 = ø 10mm <b>2 = ø 12mm</b>	<b>1=See previous page</b>	<b>B = SSI Binary</b> G = SSI Gray  E = SSI Gray + SinCos 2048 1Vpp  A = BissC + SinCos 2048 1Vpp	1=9416 Ass <b>2=9416 Rad</b> 9=Cavo Ass 3=Cavo Rad	<b>0=None</b> 5 = 5Volt Z= Reset (uscite B e G)		Single Turn	Multi turn	
									<b>12</b>	<b>12</b>	
									13		
									14		
									17		

Preferably versions are printed in bold type

## Connections

Cable	Contact 12P IP65		
<b>Browne</b>	<b>1</b>	<b>0V</b>	0V
<b>Pinh</b>	<b>2</b>	<b>DATA+</b>	Output Data +
<b>Yellow</b>	<b>3</b>	<b>CLOCK+</b>	Input Clock +
<b>White/Green</b>	<b>4</b>	<b>A</b>	Channel A (SinCos version)
<b>Blue</b>	<b>5</b>	<b>UP/DOWN</b>	Up Down
<b>Red/Blu</b>	<b>6</b>	<b>B</b>	Channel B (SinCos version)
<b>Browne/Green</b>	<b>7</b>	<b>A-</b>	Channel A- (SinCos version)
<b>White</b>	<b>8</b>	<b>+VCC</b>	+Vcc
<b>Grey/Pink</b>	<b>9</b>	<b>B-</b>	Channel B- (SinCos version)
<b>Grey</b>	<b>10</b>	<b>DATA-</b>	Output Data -
<b>Green</b>	<b>11</b>	<b>CLOCK-</b>	Input Clock -
<b>Black</b>	<b>12</b>	<b>GND OUT</b>	Internally connected with Pin 1. Use to lay Up/Dwon on 0V if required

**RESET OPTION:** Reset bottom on the cover